

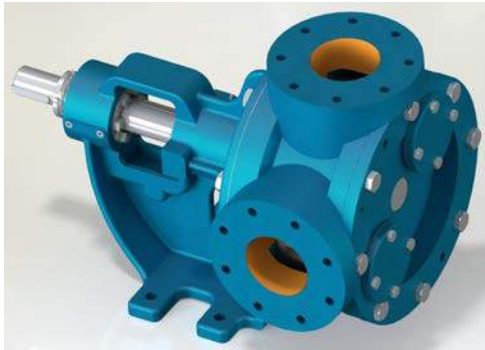

3" GRSJ Internal Eccentric Gear Pump



Performance:

Flow rate	55 m ³ /h
Pressure	1 - 14 bar
Temperature	0 - 200 °C
Speed	400 d/d
Viscosity	100 - 250000 SSU

Technical Features:

- ✓ Internal eccentric gear pump
- ✓ 3" flanged ports
- ✓ Compact design
- ✓ Reliable construction thanks to only two moving parts
- ✓ Various material options
- ✓ Available with external bypass, jacketed and blind cover
- ✓ 230v, three phase 50/60hz motors available
- ✓ Gearbox and belt pulley drive available
- ✓ Manufactured according to CE regulations

Applications:

- ✓ Fuel oil, diesel fuel and gas oil transfer
- ✓ Small scale thermal oil applications including Marlotherm, Duratherm, Paratherm, Multitherm, Mobiltherm and Dowtherm
- ✓ Lubrication applications
- ✓ Coolant transfer
- ✓ Any transfer of low to medium viscosity fluids with lubricating properties
- ✓ Not suitable for fluids containing abrasive particles

Material Options:

- ✓ Pump body, covers: Pig cast iron, Spheroidal cast iron, cast steel, AISI 304/316 CrNi Stainless Steel
- ✓ Gears: Spheroidal cast iron, cast steel, AISI 304/316 CrNi Stainless Steel
- ✓ Bearings: Snbz 12 bronze, carbon graphite, silicon carbide, hard metal coated steel, bearing
- ✓ Sealing: Soft seal or packing gland, Rotatherm seal, lip seal, mechanical seal, cartridge type mechanical seal

Capacity & Power Table						
Capacity (Q)	Speed (rpm)	Pressure				Viscosity
		2.5 Bar	5 Bar	7.5 Bar	10 Bar	
8	60	5.5 HP	5.5 HP	7.5 HP	7.5 HP	75000 SSU
10	80	7.5 HP	7.5 HP	10 HP	10 HP	25000 SSU
12	100	7.5 HP	10 HP	10 HP	10 HP	25000 SSU
34	250	15 HP	20 HP	25 HP	30 HP	25000 SSU
42	300	15 HP	20 HP	25 HP	30 HP	7500 SSU
50	350	15 HP	20 HP	25 HP	30 HP	2500 SSU
55	400	15 HP	20 HP	25 HP	30 HP	750 SSU





Pump Dimensions - Capacity Graphs:

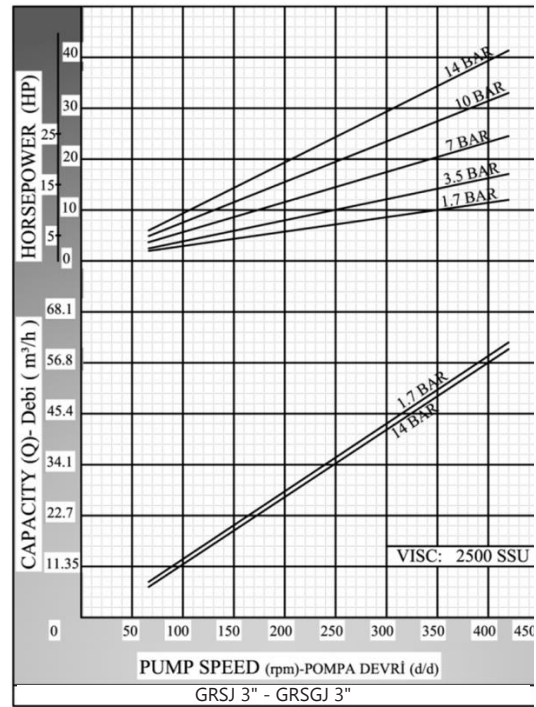
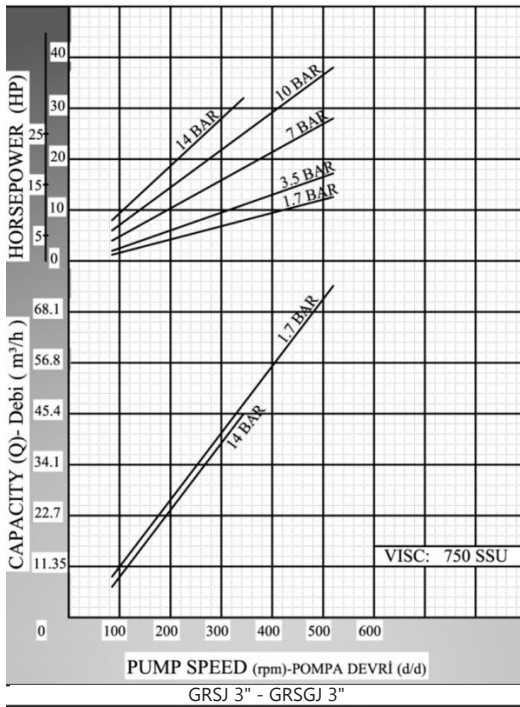
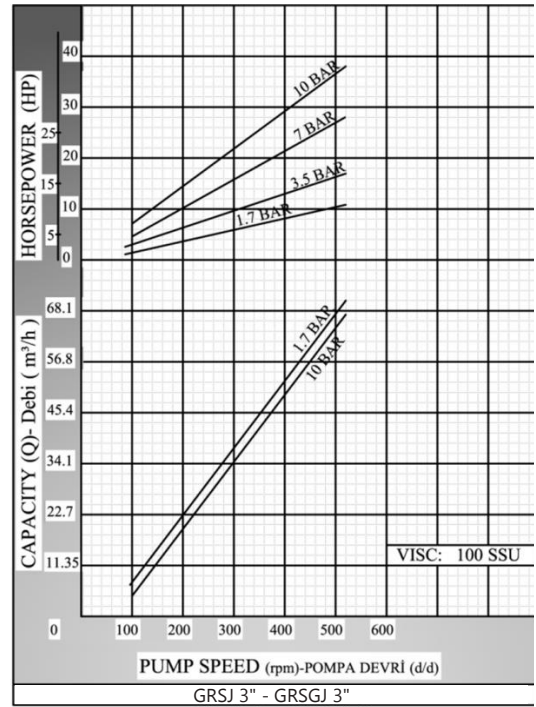
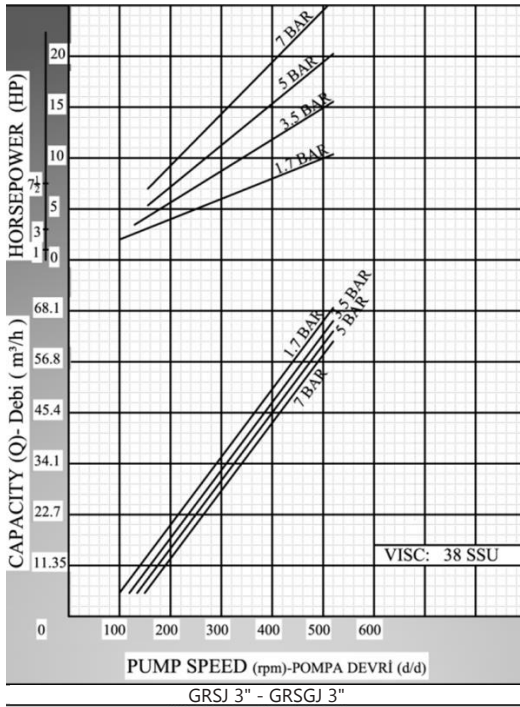

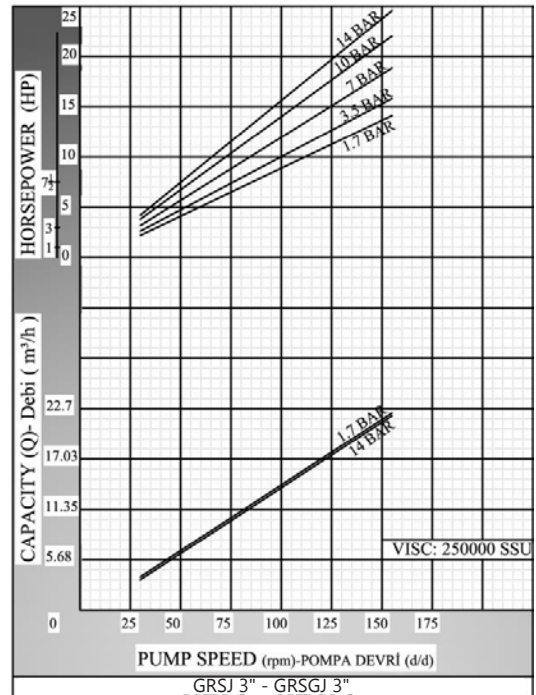
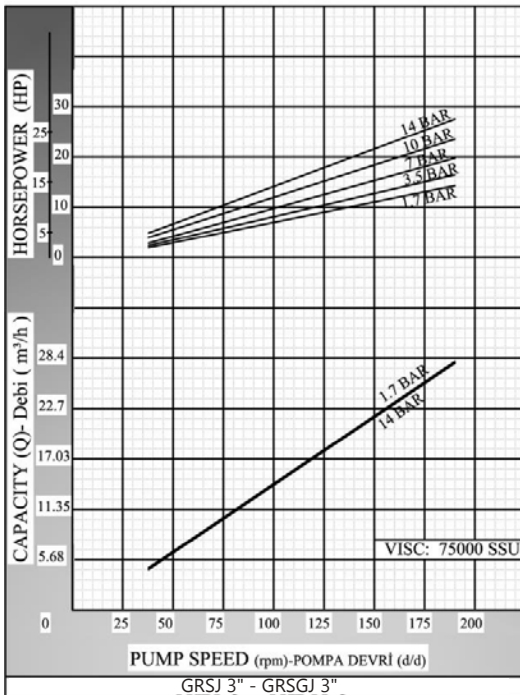
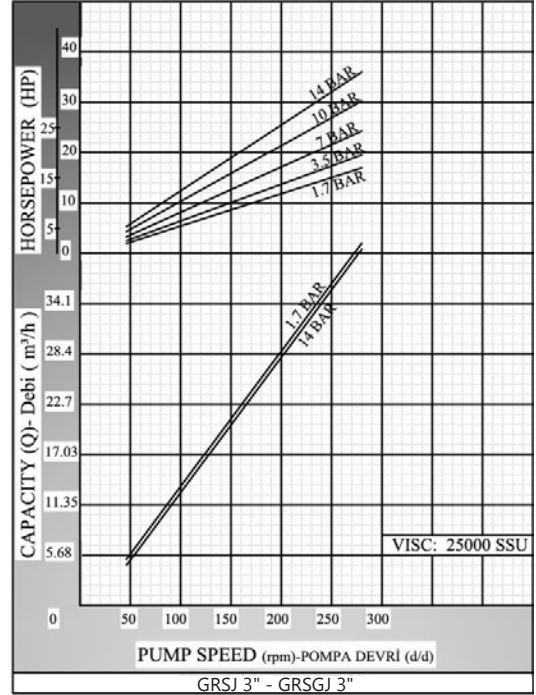
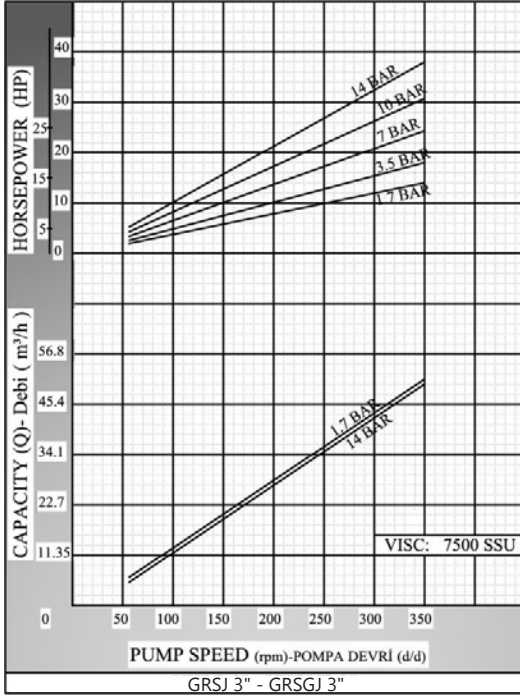



Pump Dimensions:

GRSJ 3"

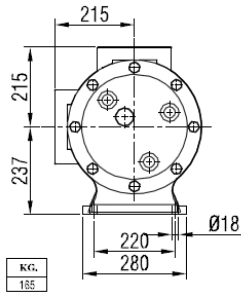

GRSJ 3"

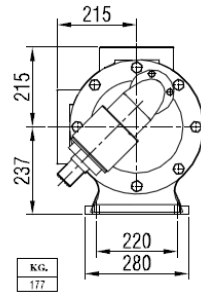

GRSGJ 3"

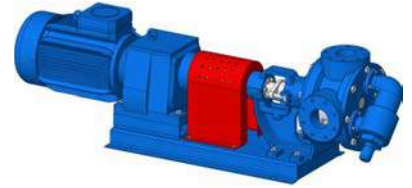
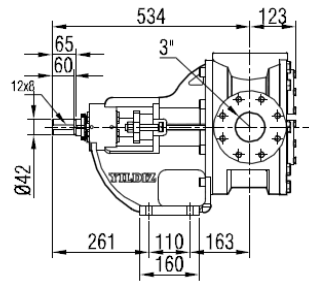
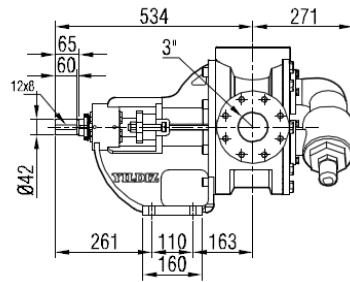
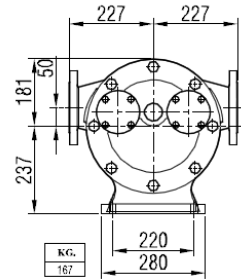

Coupling Dimensions - Gearbox drive:

GRSJ 3"

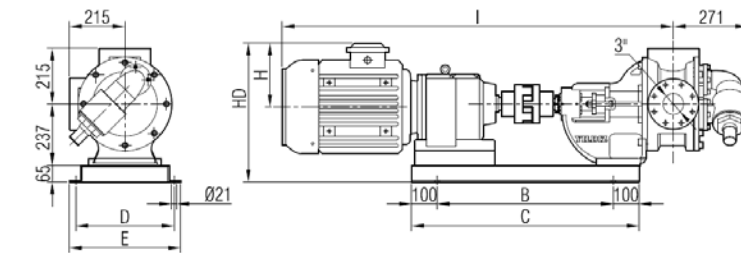

GRSGJ 3"

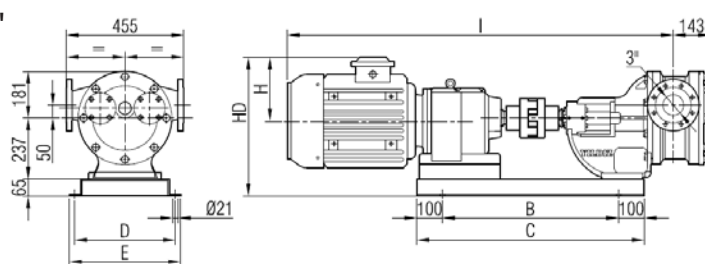

Motor Power & Speed			I	HD	H	B	C	D	E	Kg
15 hp / 11 kw	200/400 d/d (rpm)	IRAM72/C132M	1295	468	182	580	780	380	420	340
20 hp / 15 kw	130/400 d/d (rpm)	IRAM82/160L	1500	513	225	680	880	390	430	400
25 hp / 18.5 kw	159/400 d/d (rpm)	IRAM82/180M	1512	538	248					415
30 hp / 22 kw	55/400 d/d (rpm)	IRAM102/180L	1705	542	248	880	1080	480	520	670

GRSJ 3"

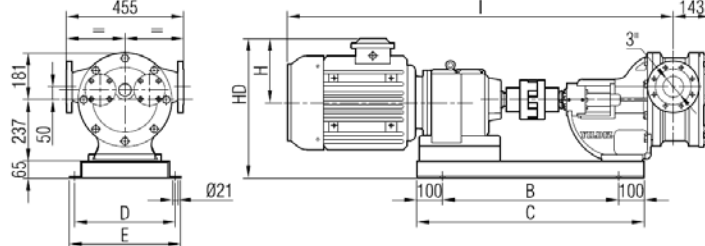

Motor Power & Speed			I	HD	H	B	C	D	E	Kg
5.5 hp / 4 kw	55/95 d/d (rpm)	IRAM73/C100L	1202	427	141	580	780	380	420	290
7.5 hp / 5.5 kw	75/95 d/d (rpm)	IRAM73/C112M	1222	435	149					295
10 hp / 7.5 kw	93/104 d/d (rpm)	IRAM72/132M	1315	468	182					315
10 hp / 7.5 kw	57/91 d/d (rpm)	IRAM83/132M	1390	460		680	880	390	430	350
15 hp / 11 kw	40/57 d/d (rpm)	IRAM93/160M	1542	505	225	830	1030	420	460	460



Belt Pulley Coupling Pump Dimensions:

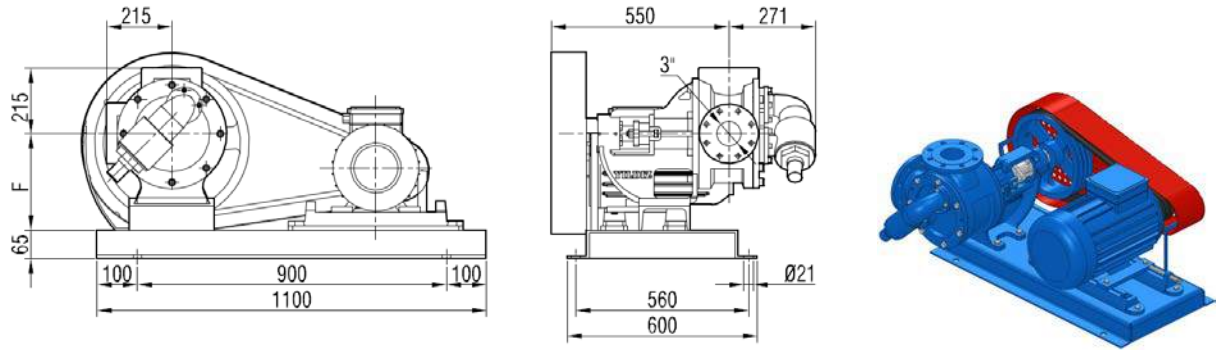

Motor Power & Speed		Pump Speeds				F ₍₁₎	F ₍₂₎	F ₍₃₎	F ₍₄₎	Kg
		N1 d/d	N2 d/d	N3 d/d	N4 d/d					
15 hp / 11 kw	MOTOR 160M	450	400	350	310	237	237	237	237	375
20 hp / 15 kw	MOTOR 160L									385
25 hp / 18.5 kw	MOTOR 180M									410
30 hp / 22 kw	MOTOR 180L									425

Spare Parts List - Sealed with soft seal, and pressure relief valve on cover:

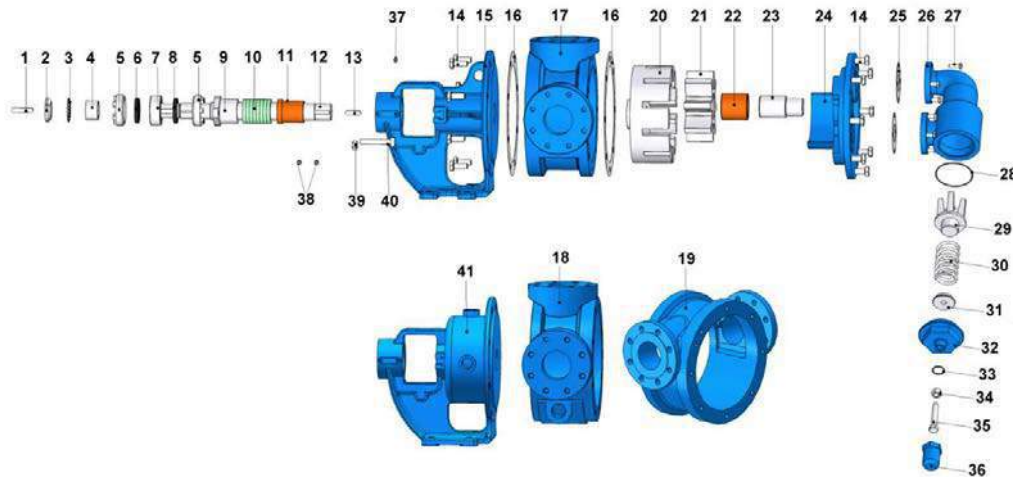

No.	Part Name.	Qty.	No.	Part Name.	Qty.	No.	Part Name.	Qty.
1	Coupling Key 12x8x60 AB	1	15	Bracket	1	29	Valve	1
2	Lock Nut	1	16	Bracket & Cover Gasket	2	30	Spring	1
3	Lock Washer	1	17	Casing (w/ 90° Flanged Ports)	1	31	Washer	1
4	Spacer	1	18	Casing (w/ 90° Flanged & w/ Heating Jacket)	1	32	Bypass Cover	1
5	Adjusting Nut	2	19	Casing (w/ 180° Flanged Ports)	1	33	Cap O-Ring	1
6	Lip Seal $\phi 55 \times \phi 72 \times \phi 10$	1	20	Rotor Gear	1	34	Nut M16	1
7	Ball Bearing (3209)	1	21	Idler Gear	1	35	Adjusting Screw M16x90	1
8	Lip Seal $\phi 50 \times \phi 72 \times \phi 10$	1	22	Idler Bushing	1	36	Cap	1
9	Packing Press	1	23	Cover Pin	1	37	Greasing Fitting R3/8"	1
10	Soft Seal / Packing Gland	1 TK	24	Cover	1	38	Grub Screw M12x16	4
11	Bracket Bushing	1	25	Bypass Gasket	2	39	Nut M14	2
12	Shaft	1	26	Pressure Relief Valve - Bypass	1	40	Square Screw M14x90	2
13	Rotor Key 12x8x45 A	1	27	Hex Bolt M10x30	8	41	Bracket (w/ Heating Jacket)	1
14	Hex Bolt M16 x 40	16	28	Bypass O-Ring	1			



Spare Parts List - Sealed with soft seal, jacketed, and with blind cover:

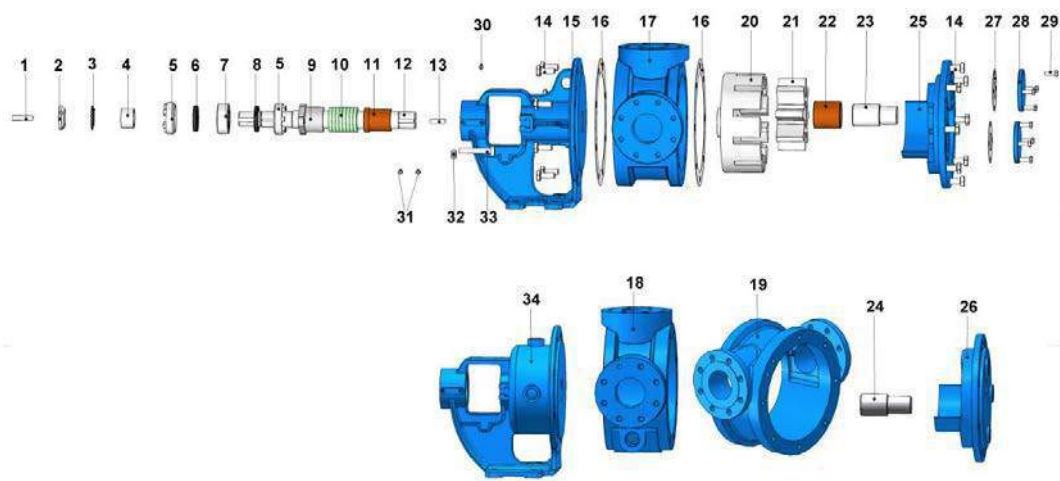

No.	Part Name.	Qty.	No.	Part Name.	Qty.	No.	Part Name.	Qty.
1	Coupling Key 12x8x60 AB	1	13	Rotor Key 12x8x45 A	1	25	Cover	1
2	Lock Nut	1	14	Hex Bolt M16x40	16	26	Jacketed Cover	1
3	Lock Washer	1	15	Bracket	1	27	Bypass Gasket	2
4	Spacer	1	16	Bracket & Cover Gasket	2	28	Bypass Inlets Cover	2
5	Adjusting Nut	2	17	Casing (w/ 90° Flanged Ports)	1	29	Hex Bolt M10x30	8
6	Lip Seal ø55xø72x10	1	18	Casing (w/ 90° Flanged Ports & w/ Heating Jacket)	1	30	Greasing Fitting R3/8"	1
7	Ball Bearing (3209)	1	19	Casing (w/ 180° Flanged Ports)	1	31	Grub Screw M12x16	4
8	Lip Seal ø50xø72x10	1	20	Rotor Gear	1	32	Nut M14	2
9	Packing Press	1	21	Idler Gear	1	33	Square Screw M14x90	2
10	Soft Seal / Packing Gland	1 TK	22	Idler Bushing	1	34	Bracket (w/ Heating Jacket)	1
11	Bracket Bushing	1	23	Cover Pin	1			
12	Shaft	1	24	Jacketed Cover Pin	1			

Spare Parts List - Sealed with mechanical seal, and pressure relief valve on cover:

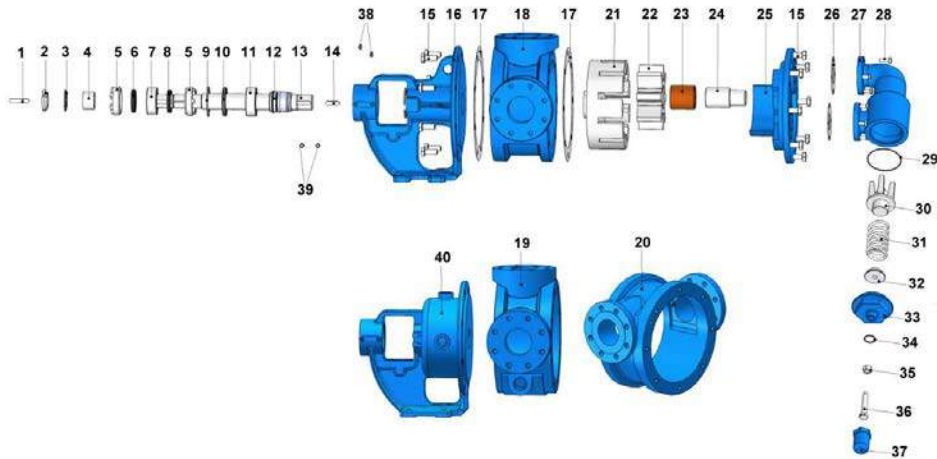

No.	Part Name.	Qty.	No.	Part Name.	Qty.	No.	Part Name.	Qty.
1	Coupling Key 12x8x60 AB	1	15	Hex Bolt M16x40	16	29	Bypass O-Ring	1
2	Lock Nut	1	16	Bracket (w/ Adjusting Nut & Mechanical Seal)	1	30	Valve	1
3	Lock Washer	1	17	Bracket & Cover Gasket	2	31	Spring	1
4	Spacer	1	18	Casing	1	32	Washer	1
5	Adjusting Nut	2	19	Casing (90° Flanged & w/ Heating Jacket)	1	33	Bypass Cover	1
6	Lip Seal ø55xø72x10	1	20	Casing (w/ 180° Flanged Ports)	1	34	Cap O-Ring	1
7	Ball Bearing (3209)	1	21	Rotor Gear	1	35	Nut M16	1
8	Lip Seal ø50xø72x10	1	22	Idler Gear	1	36	Adjusting Screw M16x90	1
9	Internal Circlip (ø90)	1	23	Idler Bushing	1	37	Cap	1
10	Lip Seal ø50xø90x10	1	24	Cover Pin	1	38	Greasing Fitting R3/8"	2
11	Bearing (3210)	1	25	Cover	1	39	Grub Screw M12x16	4
12	Mechanical Seal Ø50	1	26	Bypass Gasket	2	40	Bracket (w/ Heating Jacket)	1
13	Shaft	1	27	Pressure Relief Valve - Bypass	1			
14	Rotor Key 12x8x45 A	1	28	Hex Bolt M10x30	8			



Spare Parts List - Sealed with mechanical seal, jacketed, and with blind cover:

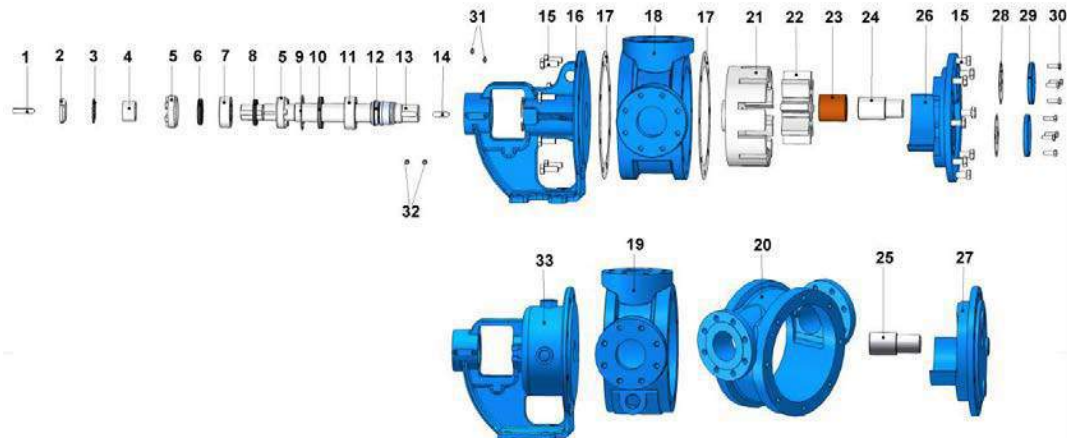

No.	Part Name.	Qty.	No.	Part Name.	Qty.	No.	Part Name.	Qty.
1	Coupling Key 12x8x60 AB	1	12	Mechanical Seal Ø50	1	23	Idler Bushing	1
2	Lock Nut	1	13	Shaft	1	24	Cover Pin	1
3	Lock Washer	1	14	Rotor Key 12x8x45 A	1	25	Jacketed Cover Pin	1
4	Spacer	1	15	Hex Bolt M16x40	16	26	Cover	1
5	Adjusting Nut	2	16	Bracket	1	27	Jacketed Cover	1
6	Lip Seal ø55xø72x10	1	17	Bracket & Cover Gasket	2	28	Bypass Gasket	2
7	Ball Bearing (3209)	1	18	Casing (w/ 90° Flanged Ports)	1	29	Bypass Inlets Cover	2
8	Lip Seal ø50xø72x10	1	19	Casing (w/ 90° Flanged & w/ Heating Jacket)	1	30	Hex Bolt M10x30	8
9	Internal Circlip (ø90)	1	20	Casing (w/ 180° Flanged Ports)	1	31	Greasing Fitting R3/8"	2
10	Lip Seal (ø50xø90x10)	1	21	Rotor Gear	1	32	Grub Screw M12x16	4
11	Bearing (3210)	1	22	Idler Gear	1	33	Bracket (w/ Heating Jacket)	1

Spare Parts List - Sealed with lip seal, jacketed, and with blind cover:

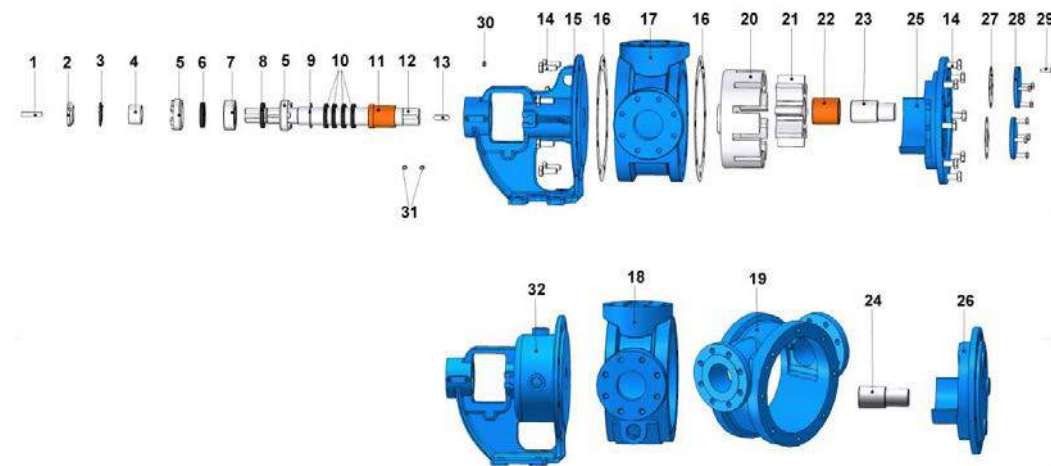

No.	Part Name.	Qty.	No.	Part Name.	Qty.	No.	Part Name.	Qty.
1	Coupling Key 12x8x60 AB	1	12	Shaft	1	23	Cover Pin	1
2	Lock Nut	1	13	Rotor Key 12x8x45 A	1	24	Jacketed Cover Pin	1
3	Lock Washer	1	14	Hex Bolt M16x40	16	25	Cover	1
4	Spacer	1	15	Bracket	1	26	Jacketed Cover	1
5	Adjusting Nut	2	16	Bracket & Cover Gasket	2	27	Bypass Gasket	2
6	Lip Seal ø55xø72x10	1	17	Casing (w/ 90° Flanged Ports)	1	28	Bypass Inlets Cover	2
7	Ball Bearing (3209)	1	18	Casing (w/ 90° Flanged & w/ Heating Jacket)	1	29	Hex Bolt M10x30	8
8	Lip Seal ø50xø72x10	1	19	Casing (w/ 180° Flanged Ports)	1	30	Greasing Fitting R3/8"	1
9	Internal Circlip (ø70)	1	20	Rotor Gear	1	31	Grub Screw M12x16	4
10	Lip Seal (ø50xø70x10)	4	21	Idler Gear	1	32	Bracket (w/ Heating Jacket)	1
11	Bracket Bushing	1	22	Idler Bushing	1			



Spare Parts List - Sealed with cartex mechanical seal, and pressure relief valve on cover:

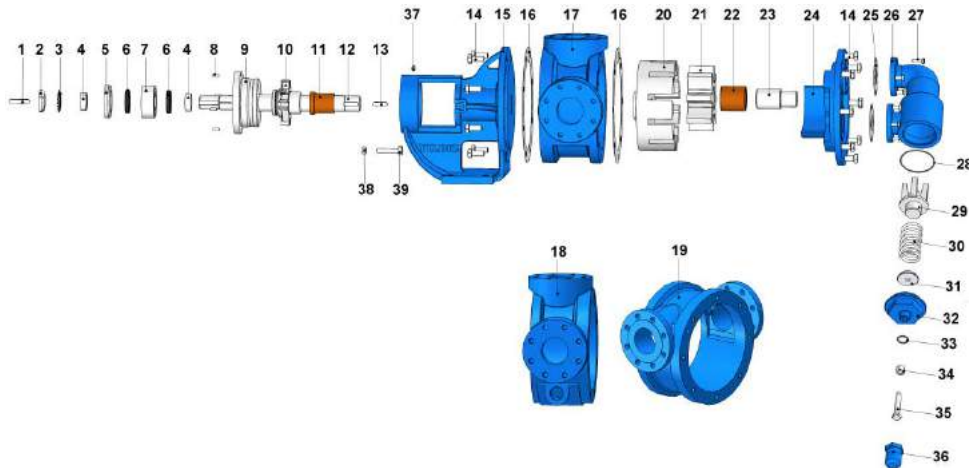

No.	Part Name.	Qty.	No.	Part Name.	Qty.	No.	Part Name.	Qty.
1	Coupling Key 12x8x60 AB	1	14	Hex Bolt M16x40	16	27	Hex Bolt M10x30	8
2	Lock Nut	1	15	Bracket (w/ Cartex Mechanical Seal)	1	28	Bypass O-Ring	1
3	Lock Washer	1	16	Bracket & Cover Gasket	2	29	Valve	1
4	Spacer	2	17	Casing (w/ 90° Flanged Ports)	1	30	Spring	1
5	Pulley Cover	1	18	Casing (90° Flanged & w/ Heating Jacket)	1	31	Washer	1
6	Lip Seal $\phi 55 \times \phi 72 \times 10$	2	19		1	32	Bypass Cover	1
7	Ball Bearing (3209)	1	20	Rotor Gear	1	33	Cap O-Ring	1
8	Grub Screw M8x20	4	21	Idler Gear	1	34	Nut M16	1
9	Pulley	1	22	Idler Bushing	1	35	Adjusting Screw M16x90	1
10	Cartex Mechanical Seal $\phi 50$	1	23	Cover Pin	1	36	Cap	1
11	Bracket Bushing	1	24	Cover	1	37	Greasing Fitting R3/8"	1
12	Shaft	1	25	Bypass Gasket	2	38	Grub Screw M14	2
13	Rotor Key 12x8x45 A	1	26	Pressure Relief Valve - Bypass	1	39	Square Screw M14x90	2

Spare Parts List - Sealed with cartex mechanical seal, jacketed and with blind cover:

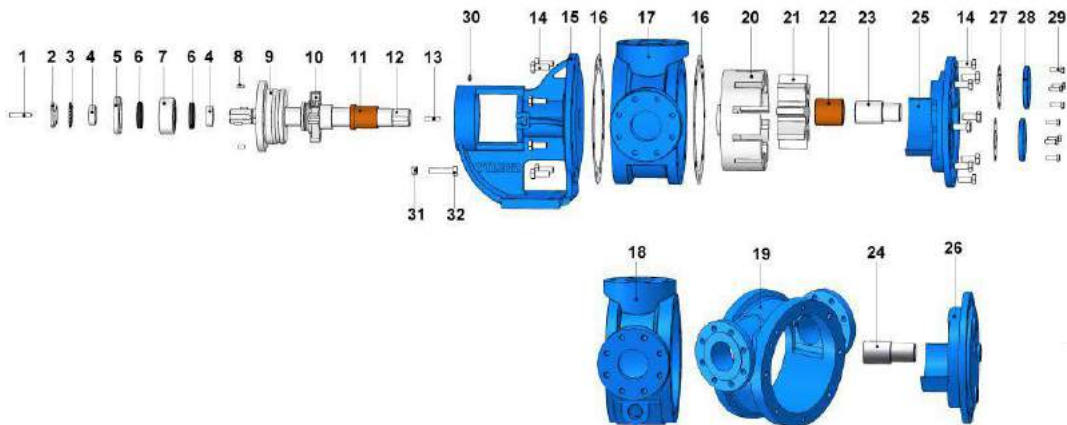

No.	Part Name.	Qty.	No.	Part Name.	Qty.	No.	Part Name.	Qty.
1	Coupling Key 12x8x60 AB	1	12	Shaft	1	23	Cover Pin	1
2	Lock Nut	1	13	Rotor Key 12x8x45 A	1	24	Jacketed Cover Pin	1
3	Lock Washer	1	14	Hex Bolt M16x40	16	25	Cover	1
4	Spacer	2	15	Bracket (w/ Cartex Mechanical Seal)	1	26	Jacketed Cover	1
5	Pulley Cover	1	16	Bracket & Cover Gasket	2	27	Bypass Gasket	2
6	Lip Seal $\phi 55 \times \phi 72 \times 10$	2	17	Casing (w/ 90° Flanged Ports)	1	28	Bypass Inlets Cover	2
7	Ball Bearing (3209)	1	18	Casing (w/ 90° Flanged & w/ Heating Jacket)	1	29	Hex Bolt M10x30	8
8	Grub Screw M8x20	4	19	Casing (w/ 180° Flanged Ports)	1	30	Greasing Fitting R3/8"	1
9	Pulley	1	20	Rotor Gear	1	31	Nut M14	2
10	Cartex Mechanical Seal $\phi 50$	1	21	Idler Gear	1	32	Square Screw M14x90	2
11	Bracket Bushing	1	22	Idler Bushing	1			